

Licensing Sub-Committee Report

Item No:	
Date:	4 th April 2017
Licensing Ref No:	17/00570/LIPN - New Premises Licence
Title of Report:	Pearl Of London - Passenger Vessel Millbank Millennium Pier Millbank London SW1P 4QP
Report of:	Director of Public Protection and Licensing
Wards involved:	Vincent Square
Policy context:	City of Westminster Statement of Licensing Policy
Financial summary:	None
Report Author:	Miss Heidi Lawrance Senior Licensing Officer
Contact details	Telephone: 020 7641 2751 Email: hlawrance@westminster.gov.uk

1. Application

1-A Applicant and premises			
Application Type:	New Premises Licence, Licensing Act 2003		
Application received date:	18 January 2017		
Applicant:	London Party Boats Ltd		
Premises:	Pearl Of London - Passenger Vessel		
Premises address:	Millbank Millennium Pier Millbank London SW1P 4QP	Ward:	Vincent Square
		Cumulative Impact Area:	None.
Premises description:	<p>The premises is a 'Party Boat' operating on the River Thames, departing on different dates and times from different Piers and Boroughs. At the end of each day the vessel will return to Millbank Pier where it will moor overnight.</p> <p>This application was scheduled to be considered by Licensing Sub-Committee on 23rd March 2017. However, the Metropolitan Police were made aware of an incident involving the applicant on 22nd March but had limited information as to the circumstances.</p> <p>As this incident involved the applicant it was agreed that the application would be adjourned so that matters could be investigated further.</p>		
Premises licence history:	This is an application for a new premises licence.		
Applicant submissions:	None submitted.		

1-B Proposed licensable activities and hours							
Live Music:				Indoors, outdoors or both			Both
Day:	Mon	Tues	Wed	Thur	Fri	Sat	Sun
Start:	07:00	07:00	07:00	07:00	07:00	07:00	07:00
End:	01:00	01:00	01:00	01:00	01:00	01:00	01:00
Seasonal variations/ Non-standard timings:				None applied for.			

Seasonal variations/ Non-standard timings:	None applied for.
Adult Entertainment:	Not Applicable

2. Representations

2-A Responsible Authorities	
Responsible Authority:	Metropolitan Police Service
Representative:	PC Bryan Lewis
Received:	2 nd February 2017
<p>With reference to the above application I am writing to inform you that the Police, as a Responsible Authority, object to your application for a new premises licence as it is our belief that if granted the application may undermine the Licensing Objectives contained in the 2003 Licensing Act.</p> <p>Our objections relate to the follow:</p> <p>No licence conditions have been proposed to promote the licensing objectives.</p> <p>The hours sought for the sale of alcohol are beyond Westminster City Council core hours as defined by the WCC Statement of Licensing Policy 2016.</p> <p>More information is required to assess this application.</p> <p><i>Please see MET Police additional submissions at Appendix 6.</i></p>	
Responsible Authority:	Environmental Health Consultation Team
Representative:	Ms Nicola Curtis
Received:	3 rd February 2017
<p>The applicant has submitted the following plan for the premises:</p> <ul style="list-style-type: none"> ◆ MV Gosport Queen Safety Plan: drawing number GQ-01, Dated 19/3/1989 <p>This representation is based on the plans and Operating Schedule submitted.</p> <p>The applicant is seeking the following licensable activities:</p> <ol style="list-style-type: none"> 1. The provision of Regulated Entertainment both indoors and outdoors Monday to Sunday 0700 to 0100 hours comprising: <ol style="list-style-type: none"> a. Live Music 	

- b. Recorded Music
 - c. Performance of Dance
 - d. Provision of anything of a similar description to live music, recorded music or performances of dance
2. The provision of Late Night Refreshment both indoors and outdoors Monday to Sunday 2300 to 0300 hours
 3. The Supply of Alcohol both 'on' and 'off' the premises Monday to Sunday 0700 to 0100 hours

I wish to make the following representations in relation to the above application:

1. The provision of Regulated Entertainment both indoors and outdoors, and the hours requested for these activities will have the likely effect of causing an increase in Public Nuisance in the area and may impact upon Public Safety.
2. The provision of Late Night Refreshment both indoors and outdoors, and the hours requested for this activity will have the likely effect of causing an increase in Public Nuisance in the area.
3. The Supply of Alcohol both 'on' and 'off' the premises and the hours requested for this activity will have the likely effect of causing an increase in Public Nuisance in the area and may impact upon Public Safety.

The applicant has provided additional information and conditions with the operating schedule which is being considered but does not fully address the concerns of Environmental Health.

The applicant is advised to contact the undersigned to arrange a suitable time for inspection of the premises and to discuss the application.

The granting of the new Premises Licence as presented would have the likely effect of causing an increase in Public Nuisance in the area and may impact on Public Safety.

Following the agreement of conditions, Environmental Health have now withdrawn their representation.

3. Policy & Guidance

The following policies within the City Of Westminster Statement of Licensing Policy apply:	
Policy HRS1 applies	(i) Applications for hours within the core hours set out below in this policy will generally be granted, subject to not being contrary to other policies in the Statement of Licensing Policy. (ii) Applications for hours outside the core hours set out below in this policy will be considered on their merits, subject to other relevant policies.
Policy PB1 applies:	Applications will only be granted if it can be demonstrated that the proposal meets the relevant criteria in Policies CD1, PS1, PN1 and CH1.
Policy MD1 applies:	Applications will only be granted if it can be demonstrated that the proposal meets the relevant criteria in Policies CD1, PS1, PN1 and CH1.
Policy FFP1 applies:	Applications will only be granted if it can be demonstrated that the proposal meets relevant criteria in Policies CD1, PS1, PN1 and CH1.

4. Appendices

Appendix 1	Premises plans
Appendix 2	Applicant supporting documents
Appendix 3	Premises history
Appendix 4	Proposed conditions
Appendix 5	Residential map and list of premises in the vicinity
Appendix 6	MET Police additional submissions

Report author:	Miss Heidi Lawrance Senior Licensing Officer
Contact:	Telephone: 020 7641 2751 Email: hlawrance@westminster.gov.uk

If you have any queries about this report or wish to inspect one of the background papers please contact the report author.

Background Documents – Local Government (Access to Information) Act 1972

1	Licensing Act 2003	N/A
2	City of Westminster Statement of Licensing Policy	7 th January 2016
3	Amended Guidance issued under section 182 of the Licensing Act 2003	March 2015
4	Application Form	18 th January 2017
5	Representation – MET Police	2 nd February 2017
6	Representation – EH	3 rd February 2017

Premises Plans

DETAILS OF SHIPS - GOSPORT QUEEN CLASS - SEE ALSO IN SECTION 3

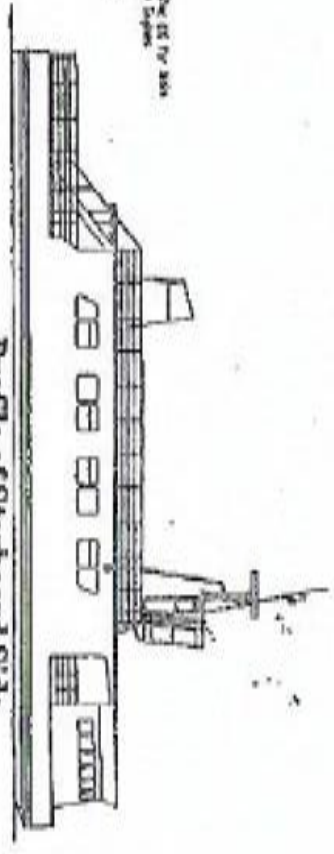
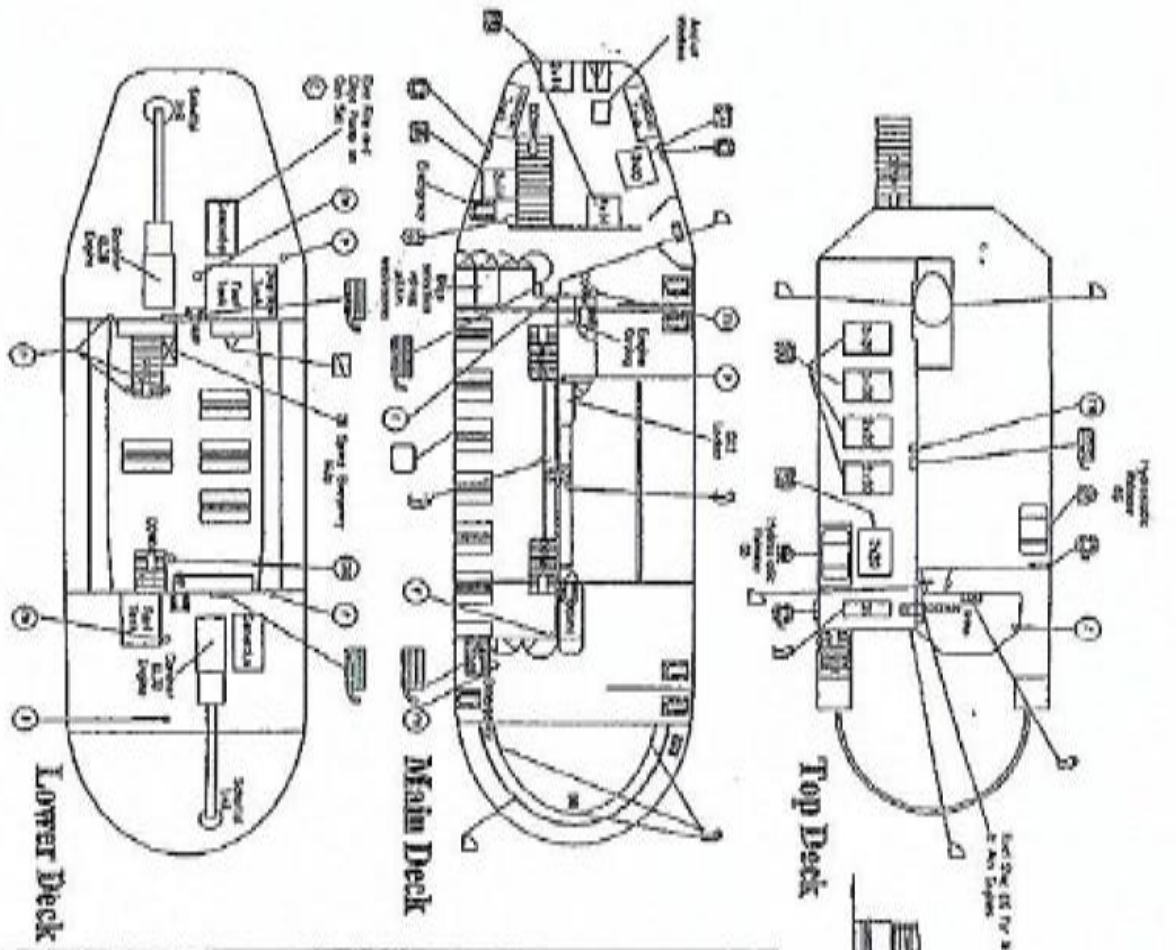

Key

- ④ Buoyancy aids : number indicates quantity
- ⑤ Type 100 4278
- ⑥ Urinebooy with smoke float 12
- ⑦ Urinebooy with 100 12
- ⑧ Urinebooy : number indicates capacity 12
- ⑨ Buoyant Apparatus : number indicates capacity
- ⑩ Fire Extinguisher : Dry Powder
- ⑪ Fire Extinguisher : Foam
- ⑫ Directed Transformer 12
- ⑬ Fire Extinguisher : CO2
- ⑭ Fire Hydrant 15
- ⑮ Fire Pump 15
- ⑯ Fire Hose 15
- ⑰ Life
- ⑱ Life
- ⑲ Air Pump/Sua & Lamps
- ⑳ Emergency Escape Routes

M.V. Gosport Queen

Ship No 380129 Call Sign GUKZM
 G.R.T. 1,014.2617M
 Beam 8.44M
 Draft 1.53M
 Speed 9 Knots
 Class 4 Passengers and crew
 Class 5 250 Passengers and 3 crew
 Class 6 Passengers and crew

Safety Plan

Date	Signature	Position
Dec 1989		
Dec 1989		
Dec 1989		

Applicant Supporting Documents**Risk Ratings to Complete Event Booking Risk Assessment Form**

Sections	Description	Risk Rating
1	Public Ticket Sales	5
	Closed Ticket Sales	4
	Football Transfer	6
	Wedding	2
	Corporate	4
	Promoted Event	6
	Student Party (Under 18)	4
	Student Party (Over 18)	6
Birthdays	0-12	0
	13-15	3
	16-17	4
	18-21	6
	22-35	5
	36-50	4
	51+	1
1a	Day Event (Finishing by 5pm)	4
	7-11	4
	8-12	5
	9-1	6
2a	Cash Bar	5
2b	Account Bar	5
2c	All Inclusive	5
2d	Tokens	4
2e	Reception Drinks	4
3a	Our Caterers	1
3b	No Catering	2
3c	Own Catering	4
4a	Our DJ	2
4b	Own DJ's	6
4c	Plug in IPod	2
4d	Live Band	5

Risk Rating

0 – No Risk

1 – No-Low Risk

2 – Low Risk

3 – Low-Medium Risk

4 – Medium Risk

5 – Medium-High Risk

6 – High Risk

7 – Too High Risk



LONDON PARTY BOATS LTD

Event Booking Risk Assessment

This form is to be completed for all events and risk scored per our company guidelines.

Event Type:		Vessel:		Date of Event:	
Clients Name:		Clients D.O.B:		Clients Contact Number:	
Date Completed:		Completed by:		Ref:	
Which Football team?					

Any previous bookings? If so what vessel/date.

Please highlight each choice within the sections.
Please dictate event time in comments section (1a).

Section	Event Details	Risk Level	Control Measures Required	Y	N	Comments
1			<ul style="list-style-type: none"> ➤ Has Security been confirmed? ➤ Will there be under 18's attending? ➤ Are wristbands required? ➤ Are tickets being sold for the event? ➤ Are the tickets being sold to the public? ➤ Have you confirmed where tickets are being sold and checked the advertisement? ➤ Is the functions times within our age policy restrictions? 			
1a	Event Time					
2	Bar					
2a	Cash Bar					
2b	Account					
2c	Drinks Package					
2d	Tokens					

Event Booking Risk Assessment

This form is to be completed for all events and risk scored per our company guidelines.

2e	Reception Drinks						
3	Catering						
3a	Our Caterers						
3b	No Catering						
3c	Own Catering						
4	Entertainment						
4a	Our DJ						
4b	Own DJ			➤ Do you have the DJ/DJ's contact details? ➤ Has a 696 been completed?			
4c	Plug in iPod						
4d	Live Band			➤ Do you have the bands contact details? ➤ Has a 696 been completed?			
4e	Other Entertainment						



Risk Level

- 0 – No Risk
- 1 – No-Low Risk
- 2 – Low Risk
- 3 – Low-Medium Risk
- 4 – Medium Risk
- 5 – Medium-High Risk
- 6 – High Risk
- 7 – Too High Risk

Has a 696 Form been completed?	Y/N	Comments:					
Final Risk Rating			(place colour score accordingly)				

Event Booking Risk Assessment

This form is to be completed for all events and risk scored per our company guidelines.

	21-35 Medium Risk Event
	36-49 High Risk Event
	50 Booking Refused

New Enquiry – Questions to ask



QUESTIONS	GUIDANCE NOTES
What's the nature of your event?	<ul style="list-style-type: none"> ➤ If a birthday, ask the age. ➤ Security must be required on all 21 and under events. ➤ Under 18 events, soft drink bar only. ➤ 18th Birthdays – Wristband system must be implemented, 70% must be over 18 with valid ID in order to sell alcohol. ➤ Promotion / Ticketed / Football Transfer events must have security.
How many people will be attending?	<ul style="list-style-type: none"> ➤ London Belle (max 125 passengers) ➤ Jewel of London (max 240 passengers) ➤ Pearl of London (max 360 passengers) ➤ Security – Belle x2 Always Jewel 150 guests x2 Jewel 150 - 250 guests x3 Pearl 250 - 300 guests x4 Pearl 300 – 360 guests x6
What date and time are you interested in hiring?	<ul style="list-style-type: none"> ➤ Under 21 events, Monday-Wednesday hire available only, Security required. ➤ Under 18 events must finish by 10pm.
Have you hired the vessel previously?	<ul style="list-style-type: none"> ➤ Check previous booking details.
Will you be selling tickets to the public for your event?	<ul style="list-style-type: none"> ➤ If yes, security must be included. ➤ Check age restriction of tickets. ➤ Find out where tickets will be advertised and check advertisement.
What are your entertainment requirements?	<ul style="list-style-type: none"> ➤ If providing own DJ's or live band, request information to fill out 696 form. ➤ iPod option must have a set playlist.
Will you be having catering?	<ul style="list-style-type: none"> ➤ Own catering – explain this is food only, no beverages included with own catering.
What bar service will you require?	<ul style="list-style-type: none"> ➤ Soft drinks package is available for all under 18 or non-alcohol events. ➤ Account bars can be supplied, payment required prior to service. ➤ Drink Tokens are available on all over 21 events. ➤ No reception drinks or tokens available on 18 and under events.

LPB Bookings 2004 - 2017			
Years	Number of Bookings	Serious Incidents	Average Passengers Carried
2004	31	0	1860
2005	108	0	6480
2006	90	0	5400
2007	129	0	7740
2008	103	0	6180
2009	138	0	8280
2010	108	0	6480
2011	127	0	7620
2012	121	0	7260
2013	134	0	8040
2014	171	0	30780
2015	243	0	43740
2016	283	0	50940
2017	21	1	3780
Total	1807	1	194580
Based on the above our record of serious incident reports would be 0.00055 percent			
Based on 50% Capacity			
London Belle - 60	Jewel of London - 120		

Premises History

There is no licence or appeal history for the premises.

CONDITIONS CONSISTENT WITH THE OPERATING SCHEDULE AND CONDITIONS PROPOSED BY A PARTY TO THE HEARING

When determining an application for a new premises licence under the provisions of the Licensing Act 2003, the licensing authority must, unless it decides to reject the application, grant the licence subject to the conditions which are indicated as mandatory in this schedule.

At a hearing the licensing authority may, in addition, and having regard to any representations received, grant the licence subject to such conditions which are consistent with the operating schedule submitted by the applicant as part of their application, or alter or omit these conditions, or add any new condition to such extent as the licensing authority considers necessary for the promotion of the licensing objectives.

This schedule lists those conditions which are consistent with the operating schedule, or proposed as necessary for the promotion of the licensing objectives by a responsible authority or an interested party as indicated. These conditions have not been submitted by the licensing service but reflect the positions of the applicant, responsible authority or interested party and have not necessarily been agreed

Mandatory Conditions

1. No supply of alcohol may be made at a time when there is no designated premises supervisor in respect of this licence.
2. No supply of alcohol may be made at a time when the designated premises supervisor does not hold a personal licence or the personal licence is suspended.
3. Every supply of alcohol under this licence must be made or authorised by a person who holds a personal licence.
4.
 - (1) The responsible person must ensure that staff on relevant premises do not carry out, arrange or participate in any irresponsible promotions in relation to the premises.
 - (2) In this paragraph, an irresponsible promotion means any one or more of the following activities, or substantially similar activities, carried on for the purpose of encouraging the sale or supply of alcohol for consumption on the premises—
 - (a) games or other activities which require or encourage, or are designed to require or encourage, individuals to;
 - (i) drink a quantity of alcohol within a time limit (other than to drink alcohol sold or supplied on the premises before the cessation of the period in which the responsible person is authorised to sell or supply alcohol), or
 - (ii) drink as much alcohol as possible (whether within a time limit or otherwise);
 - (b) provision of unlimited or unspecified quantities of alcohol free or for a fixed or discounted fee to the public or to a group defined by a particular characteristic in a manner which carries a significant risk of undermining a licensing objective;
 - (c) provision of free or discounted alcohol or any other thing as a prize to encourage or reward the purchase and consumption of alcohol over a period of 24 hours or less in a manner which carries a significant risk of undermining a licensing objective;

- (d) selling or supplying alcohol in association with promotional posters or flyers on, or in the vicinity of, the premises which can reasonably be considered to condone, encourage or glamorise anti-social behaviour or to refer to the effects of drunkenness in any favourable manner;
 - (e) dispensing alcohol directly by one person into the mouth of another (other than where that other person is unable to drink without assistance by reason of a disability).
5. The responsible person must ensure that free potable water is provided on request to customers where it is reasonably available.
6. (1) The premises licence holder or club premises certificate holder must ensure that an age verification policy is adopted in respect of the premises in relation to the sale or supply of alcohol.
- (2) The designated premises supervisor in relation to the premises licence must ensure that the supply of alcohol at the premises is carried on in accordance with the age verification policy.
- (3) The policy must require individuals who appear to the responsible person to be under 18 years of age (or such older age as may be specified in the policy) to produce on request, before being served alcohol, identification bearing their photograph, date of birth and either—
- (a) a holographic mark, or
 - (b) an ultraviolet feature.
7. The responsible person must ensure that—
- (a) where any of the following alcoholic drinks is sold or supplied for consumption on the premises (other than alcoholic drinks sold or supplied having been made up in advance ready for sale or supply in a securely closed container) it is available to customers in the following measures—
 - (i) beer or cider: ½ pint;
 - (ii) gin, rum, vodka or whisky: 25 ml or 35 ml; and
 - (iii) still wine in a glass: 125 ml;
 - (b) these measures are displayed in a menu, price list or other printed material which is available to customers on the premises; and
 - (c) where a customer does not in relation to a sale of alcohol specify the quantity of alcohol to be sold, the customer is made aware that these measures are available.

A responsible person in relation to a licensed premises means the holder of the premise licence in respect of the premises, the designated premises supervisor (if any) or any individual aged 18 or over who is authorised by either the licence holder or designated premises supervisor. For premises with a club premises certificate, any member or officer of the club present on the premises in a capacity that which enables him to prevent the supply of alcohol.

- 8(i) A relevant person shall ensure that no alcohol is sold or supplied for consumption on or off the premises for a price which is less than the permitted price.
- 8(ii) For the purposes of the condition set out in paragraph 8(i) above -
- (a) "duty" is to be construed in accordance with the Alcoholic Liquor Duties Act 1979;
- (b) "permitted price" is the price found by applying the formula -
- $$P = D + (D \times V)$$
- Where -
- (i) P is the permitted price,
- (ii) D is the amount of duty chargeable in relation to the alcohol as if the duty were charged on the date of the sale or supply of the alcohol, and
- (iii) V is the rate of value added tax chargeable in relation to the alcohol as if the value added tax were charged on the date of the sale or supply of the alcohol;
- (c) "relevant person" means, in relation to premises in respect of which there is in force a premises licence -
- (i) the holder of the premises licence,
- (ii) the designated premises supervisor (if any) in respect of such a licence, or
- (iii) the personal licence holder who makes or authorises a supply of alcohol under such a licence;
- (d) "relevant person" means, in relation to premises in respect of which there is in force a club premises certificate, any member or officer of the club present on the premises in a capacity which enables the member or officer to prevent the supply in question; and
- (e) "value added tax" means value added tax charged in accordance with the Value Added Tax Act 1994.
- 8(iii). Where the permitted price given by Paragraph 8(ii)(b) above would (apart from this paragraph) not be a whole number of pennies, the price given by that sub-paragraph shall be taken to be the price actually given by that sub-paragraph rounded up to the nearest penny.
- 8(iv). (1) Sub-paragraph 8(iv)(2) below applies where the permitted price given by Paragraph 8(ii)(b) above on a day ("the first day") would be different from the permitted price on the next day ("the second day") as a result of a change to the rate of duty or value added tax.
- (2) The permitted price which would apply on the first day applies to sales or supplies of alcohol which take place before the expiry of the period of 14 days beginning on the second day.

Conditions consistent with the operating schedule

9. Where it is felt to be necessary, passengers will be searched on boarding and any alcohol or drugs found will be confiscated. If necessary the people found to be in possession would be refused entry.
10. CCTV covers most disembarkation piers.
11. The bar will close fifteen minutes prior to disembarkation.
12. Any passenger under the influence of alcohol who becomes abusive to the crew or other passengers will be asked to leave the vessel. If necessary the police will be kept informed of the situation via vhf radio and the master will request them to attend the disembarkation point if assistance is needed.
13. No alcohol will be served to passengers under eighteen years of age. If they appear to be under-aged, proof of identity will be required e.g. PASS. If proof is not forthcoming, then alcohol drinks will not be served to them. If other passengers buy for them they will be asked to stop, if not they will be put ashore at the earliest opportunity.
14. We have procedures in our DSM manual covering all public safety. Under MCA/PLA regulations all crew have to be competent in navigation, fire fighting, first aid and are able to deal with all other emergency situations on board. Before every departure the crew make a mandatory safety announcement over the PA system. This informs passengers of all emergency safety exits, lifejacket stowage, and self-inflating life raft assembly points etc. Passenger numbers for each trip are recorded ashore and on board. The vessel, crew and Safety Management System are inspected and audited twice a year by the MCA. If unable to conform to their standards, the vessel's annual Passenger and Domestic Safety certificates are withdrawn, rendering the vessel unable to continue in public service until all non-conformities are rectified. River Emergency Services such as Police, Fire, Coastguard, PLA and R.N.L.I are on 24hrs continuous coverage and can be summoned by VHF radio or mobile phone for immediate assistance.
15. The crew monitors all disco music continuously and an automatic noise limiter adjusted to MCA accepted noise levels is in operation during the cruise. The noise limiter will automatically cut off the power supply to the disco apparatus if the music is too loud and can also be manually operated by the crew from the wheelhouse.
16. Disco music will not be allowed to commence until after the vessel has left any embarkation pier and will cease before the vessel arrives at any disembarkation pier.
17. Passengers are always advised by the crew to leave the vessel in a quiet and orderly fashion and not to do anything, which is liable to disturb nearby residents. In the event of any problems on board, the police will be asked to attend the disembarkation pier if necessary, to control any perceivable unruly behaviour, before the passengers allowed to go ashore.

18. Any requests from school regarding safety information, risk assessments, insurance and crew competency etc, are met as required prior to any voyage. The company insists on a minimum of one adult supervisor to 25 children of 16 years and under.
19. On any school trips or other trips where most of the passengers are under eighteen years of age, the bar will not be open unless specifically requested for the role of soft drinks. The crew are instructed to patrol all parts of the vessel at regular intervals to check for any unruly/unsafe behaviour.
20. Unaccompanied children are not allowed on board after 2000hrs. The crew will always be on the entrance/exit gate when embarkation or disembarkation is taking place.

Conditions proposed by the Environmental Health

21. Amplified music or regulated entertainment shall not take place whilst the vessel is moored at its Millbank moorings.
22. No noise shall emanate from the vessel which gives rise to a nuisance.
23. Notices shall be prominently displayed at all exits requesting patrons to respect the needs of local residents and businesses and leave the area quietly.

Conditions proposed by the Police

24. All drinking vessels used in the venue shall be polycarbonate. All drinks in glass bottles are to be decanted into polycarbonate containers or polycarbonate carafes prior to being served, with the exception of champagne or bottles of spirits with a minimum size of 70cl supplied by waiter/waitress service to tables. Staff shall clear all empty champagne and spirit bottles promptly from the tables. Customers shall not be permitted to leave their table carrying any such glass bottles or drink directly from the bottle.
25. The premises shall install and maintain a comprehensive CCTV system as per the minimum requirements of the Westminster Police Licensing Team. All entry and exit points will be covered enabling frontal identification of every person entering in any light condition. The CCTV system shall continually record whilst the premises is open for licensable activities and during all times when customers remain on the premises. All recordings shall be stored for a minimum period of 31 days with date and time stamping. Viewing of recordings shall be made available immediately upon the request of Police or authorised officer throughout the entire 31 day period.
26. A staff member from the premises who is conversant with the operation of the CCTV system shall be on the premises at all times when the premises is open. This staff member must be able to provide a Police or authorised council officer copies of recent CCTV images or data with the absolute minimum of delay when requested.

27. ~~A Challenge 24~~ or When alcohol is for sale a Challenge 25 proof of age scheme shall be operated at the premises where the only acceptable forms of identification are recognised photographic identification cards, such as a driving licence, passport or proof of age card with the PASS Hologram.
28. A record shall be kept detailing all refused sales of alcohol. The record should include the date and time of the refused sale and the name of the member of staff who refused the sale. The record shall be available for inspection at the premises by the police or an authorised officer of the City Council at all times whilst the premises is open.
29. An incident log shall be kept at the premises, and made available on request to an authorised officer of the City Council or the Police. It must be completed within 24 hours of the incident and will record the following:
 - (a) all crimes reported to the venue
 - (b) all ejections of patrons
 - (c) any complaints received concerning crime and disorder
 - (d) any incidents of disorder
 - (e) all discovery/seizures of drugs or offensive weapons
 - (f) any faults in the CCTV system, searching equipment or scanning equipment
 - (g) any refusal of the sale of alcohol
 - (h) any visit by a relevant authority or emergency service
30. Alcohol shall not be taken or consumed off the vessel at any time.
31. The bar shall close 15 minutes prior to disembarkation, after this no alcohol shall be sold. This is to be announced on the public address system.
32. Passengers shall not be allowed to bring alcohol on board the vessel
33. The crew shall make a comprehensive safety announcement over the PA system before every departure. This is to include a segment on drink aware and the ejection policy.
34. A noise limiter must be fitted to the musical amplification system set at a level determined by and to the satisfaction of an authorised officer of the Environmental Health Service, so as to ensure that no noise nuisance is caused to local residents or businesses. The operational panel of the noise limiter shall then be secured by key or password to the satisfaction of officers from the Environmental Health Service and access shall only be by persons authorised by the Premises Licence holder. The limiter shall not be altered without prior agreement with the Environmental Health Service. No alteration or modification to any existing sound system(s) should be effected without prior knowledge of an authorised Officer of the Environmental Health Service. No additional sound generating equipment shall be used on the premises without being routed through the sound limiter device.
35. Any passenger that becomes abusive/aggressive to the crew or other passengers shall be asked to leave the vessel. Such persons will be ejected at the nearest available pier. A duty of care shall be provided for the ejected persons and to consider calling the emergency services.

36. Passenger numbers for each trip should be recorded on the Ships AIS system and on-board in the Ships Diary. The capacity of the vessel shall be determined and approved by the Maritime and Coastguard Agency (MCA) and placed on the ships certificate.
37. Passengers shall be advised by the crew to leave the vessel in a quiet and orderly fashion and not to do anything which is liable to disturb nearby residents. Prominent notices shall be displayed at the entrance and exit points.
38. Non-intoxicating drinks including drinking water shall be available at all times during the permitted hours for licensable activities with the exception of bookings not requiring a bar service.
39. There shall be a personal licence holder on duty on the vessel at all times alcohol is being sold.
40. All SIA approved staff engaged in supervising or controlling queues as well as engaged in duties on board the vessel shall wear high visibility yellow jackets or vests.
41. Registered SIA security staff to be on duty during all externally promoted events including DJ's, birthday bookings where the persons birthday is 25 or under and all football related booking
42. The licence holder shall ensure that there is a written risk assessment policy in place for every event to be held on the vessel and be available for inspection by police or authorised officers
43. When SIA registered door staff are deployed there shall be a minimum of 2 always working, and an extra 1 for every additional 50 persons over 100 persons.
44. There shall be no all inclusive alcoholic drink packages.
45. A Police 696m risk assessment form shall be submitted to the Westminster Police Licensing Team and the Police Marine Unit for all externally promoted events including DJ's, birthday bookings where the persons birthday is 25 or under and all football related booking
46. The SIA staff and crew will ensure that the pier is clear of all customers prior to leaving the pier. This includes a duty of care on all persons ejected during the duration of the trip.
47. It shall be a condition of entry that the customer agrees to an outer clothing and bag search being carried out or refusal of entry will be given, and notices to that effect shall be displayed. SIA Door Supervisors on duty will action as to when and whom is searched and a record of any decisions to be made. All searching shall be supplemented by the use of metal detector wands.

Residential Map and List of Premises in the Vicinity

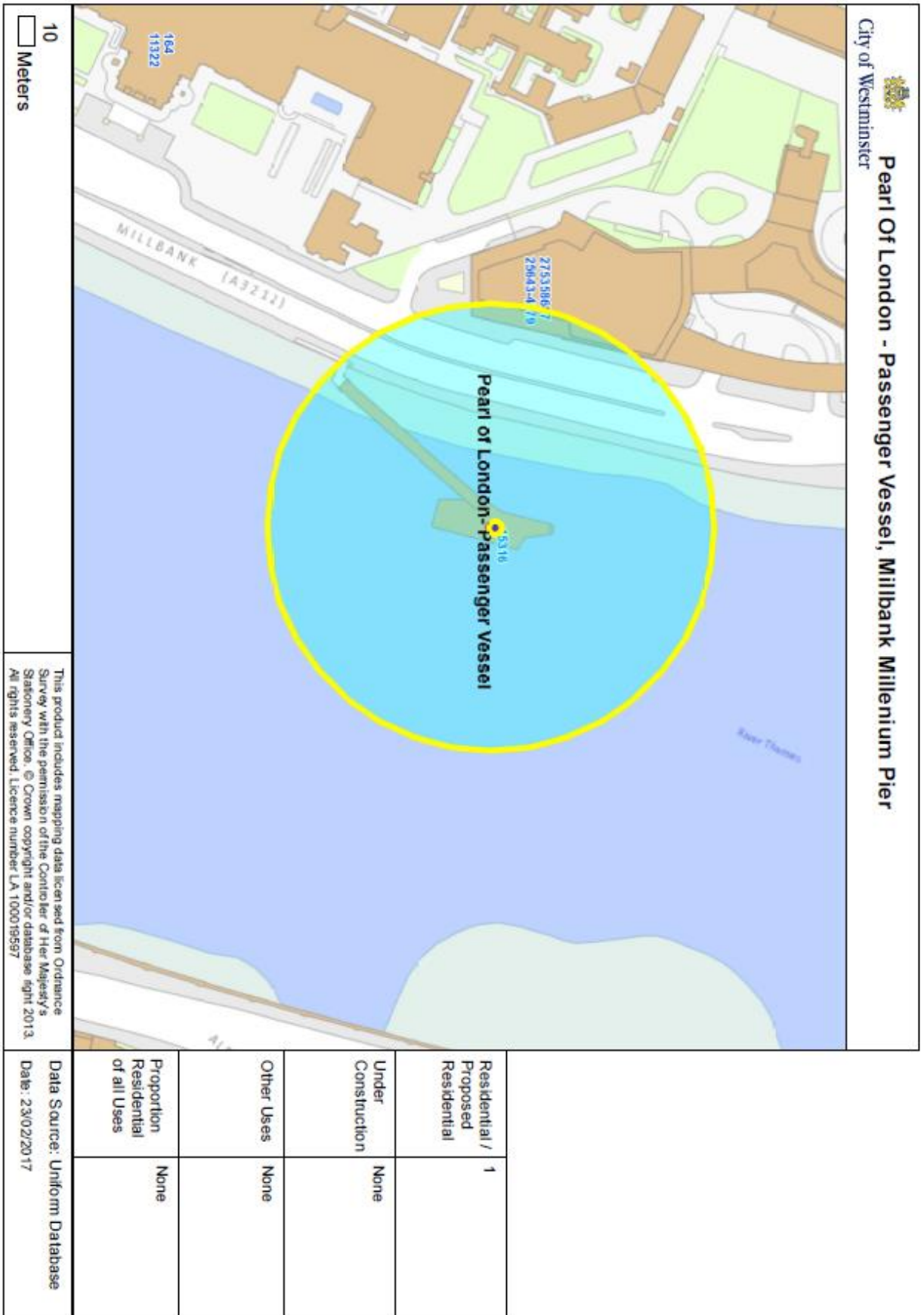

**Premises within 75 metres of: Pearl Of London - Passenger Vessel,
Millbank Millennium Pier, Millbank, SW1P 4QP**

p / n	Name of Premises	Premises Address	Licensed Hours
15316	London Belle - Passenger Vessel	London Bell Passenger Vessel Moored On Millbank Moorings At Millennium Pier Millbank London SW1P 4QP	Monday to Sunday 07:00 - 01:00

MET Police Service addition submissions

PROTECTIVE MARKING

**METROPOLITAN
POLICE****TOTAL POLICING**

Form 693

Form for Applying for a Summary Licence Review**Application for the review of a premises licence under section 53A of the Licensing Act 2003**
(premises associated with serious crime, serious disorder or both)**PLEASE READ THE FOLLOWING INSTRUCTIONS FIRST**

Before completing this form please read the guidance notes at the end of the form. If you are completing the form by hand please write legibly in block capitals. In all cases ensure that your answers are inside the boxes and written in black ink.

Use additional sheets if necessary.

Insert name and address of relevant licensing authority and its reference number:

Name:	London Borough Of Southwark Licensing Authority		
Address:	3rd Floor 160 Tooley Street		
Post town:	Southwark	Post code:	SE1 2QH
Ref. No.:			

I Police Constable Ian Clements 362MD

on behalf of the chief officer of police for the Metropolitan Police area apply for the review of a premises licence under section 53A of the Licensing Act 2003.

1. Premises details

Postal address of premises or club premises, or if none, ordnance survey map reference or description:

M/V The Jewel Of London, Kings Reach London

Post town:	Southwark	Post code: (if known)	SE1
-------------------	-----------	---------------------------------	-----

2. Premises licence details

Name of premises licence holder or club holding club premises certificate (if known):

London Party Boats Ltd

Number of premises licence or club premises certificate (if known):

845553

3. Certificate under section 53A(1)(b) of the Licensing Act 2003 (Please read guidance note 1)

I confirm that a certificate has been given by a senior member of the police force for the police area above that in his opinion the above premises are associated with serious crime or serious disorder or both, and the certificate accompanies this application.

Please tick the box to confirm:



PROTECTIVE MARKING

4. Details of association of the above premises with serious crime, serious disorder or both

(Please read guidance note 2)

On Saturday the 14th January 2017 at 2345hrs Police attended calls for assistance to a large fight on board Motor Vessel **The Jewel Of London**.

On Police arrival the vessel was docked at Westminster Pier.

In total 32 Police units attended what was reported as 150 people fighting. On arrival there were approximately 150 people contained on the vessel, the group were aggressive and attempting to jump from the boat onto the pier. For safety reasons and to facilitate the investigation they were allowed to filter off the vessel into a contained area held by the Police on scene.

Initial investigations found four males with serious injuries, one male had two large stab wounds to his back, a second with a stab wound to his head and a third with deep cuts to his hands and a 10cm slash wound across his head and cuts to his face. A fourth male appeared to have been hit with a bottle and had a cut to his eye.

CCTV from the vessel shows various males fighting with what appears to be a knife, bottles and belts. This matter is still under investigation but the initial indication is that weapons had been taken on board the vessel and or obtained and used whilst on board. This resulted in at least four males receiving injuries consistent with GBH, and five males being arrested for public order related offences.

A total of 32 Police units attended the scene, at least two paramedic units and what will be a lengthy and resource intensive investigation.

This appears to be an isolated incident, there is no evidence that the premises were operating in breach of the premises licence, however I believe it is so serious that interim measures are required for the prevention of crime and disorder.

I am of the opinion that this matter needs expediting under section 53a of the licensing act 2003, we should be asking the licensing committee to suspend the premise licence as an interim measure pending a full review hearing.

Signature of applicant

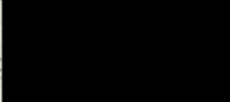
Signature:		Date:	18-01-2017
Capacity:	AC 362 ^{MP} Police Licensing Officer		
Contact details for matters concerning this application			
Surname:	CLEMENTS	First Names:	IAN
Address:			
Southwark Police Station 323 Borough High Street			
Post town:	Southwark	Post code:	SE1 1SU
Tel. No.:	0207 232 6756	Email:	ian.clements@met.police.uk

Notes for guidance

PROTECTIVE MARKING

1. A certificate of the kind mentioned in the form must accompany the application in order for it to be valid under the terms of the Licensing Act 2003. The certificate must explicitly state the senior officer's opinion that the premises in question are associated with serious crime, serious disorder or both.
Serious crime is defined by reference to section 81 of the Regulation of Investigatory Powers Act 2000. In summary, it means:
 - conduct that amounts to one or more criminal offences for which a person who has attained the age of eighteen and has no previous convictions could reasonably be expected to be sentenced to imprisonment for a term of three years or more; or
 - conduct that amounts to one or more criminal offences and involves the use of violence, results in substantial financial gain or is conduct by a large number of persons in pursuit of a common purpose.
Serious disorder is not defined in legislation, and so bears its ordinary English meaning.
2. Briefly describe the circumstances giving rise to the opinion that the above premises are associated with serious crime, serious disorder, or both.

Retention Period: 7 years
MP 198/12



'I thought I was gonna die': Revellers' terror as man stabbed during fight on Jewel of London Thames party boat

download failed

Duchatelet protest to Belgium as Addicks lose again

drops Sanchez for tactical reasons with Ozil missing

train surfer' rides moving DLR

Italy as he enjoys amazing Chelsea experience

Revellers today told how they feared for their lives when celebrations on a Thames party boat flared into violence which left three people in hospital.

One man was stabbed and two others injured when a fight broke out on board the £360-an-hour Jewel Of London as it arrived back at Westminster Pier after the "New Year's All Black Boat Party."

More than 50 police officers swarmed the vessel as paramedics wheeled one man, 21, away in a wheelchair. He remains in hospital with injuries said to be non-life threatening.

Another man was seen leaving the boat with a bandage wrapped around his head.

The event, which was advertised on Facebook with tickets costing £30, played host to several different birthdays.





The event, which was advertised on Facebook with tickets costing £10, played host to several different birthdays.



Joint Response Units
@JAS_URU

The team attended a large fight on a boat with @MPSWestminster & @CityPolice resulting in multiple injured parties.

11:20 AM - 15 Jan 2017

11 02

One party-gner, who tweeted about the incident, said: "...boat party last night was so lit but the madness that happened after was crazy I

Waiting for #JASinvestigation...



MOST POPULAR

Police hunt men over horrific homophobic attack on London-bound train

Chelsea given the green light for new £500m stadium

Man fighting for life after stabbing near east London Tube station

Shocking moment boy, 16, repeatedly stabbed by hooded thug in street

Martine McCutcheon and Hugh Grant reunited for Love

Revellers terrorised...
 www.standard.co.uk/news/other/i-thought-i-was-gonna-die-rowdy-terror-as-man-stabbed-during-fight-on-jewel-of-london-thames-party-boat-4942178.html

ES News Football Going Out Lifestyle Showbiz Homes & Property Food Month



ES

'I thought I was gonna die': Revellers' terror as man stabbed during fight on Jewel of London Thames party boat

last night was so lit but the madness that happened after was crazy I thought I was gonna die."

Sports journalist Toby Giles was walking across Westminster Bridge when he saw the disturbance.

He told the Standard: "At first I thought it must have been an exercise. There were about 12 police cars and as I was walking up I could see a lot more coming from both directions.

"The pier was closed off and I could see at least two people being treated.

"One had a bandage around his head and one was in a wheel chair wrapped in foil. You could see he was either in and out of consciousness or woozy. People were being questioned and I saw one guy in handcuffs."



Establishing secure connection...



Martine McCutcheon and Hugh Grant reunited for Love Actually sequel.



RENTALMENT

Sofa a bit squashed?
 Provided by ebay

VIDEO



Justin Timberlake dedicates iHeart Radio Award to 'different' people

Reveller's terror as man 'I thought I was gonna die': Revellers' terror as man stabbed during fight on jewel of London Thames party boat

ES News Football Going Out Lifestyle Showbiz Homes & Property Food North

ES

'I thought I was gonna die': Revellers' terror as man stabbed during fight on jewel of London Thames party boat



Stabbing: Police descended on the boat (Toby Olliss)

Footage from the event on Saturday night shows people drinking and dancing on two levels on the boat on the Thames, with heavy bass playing in the background.

One of the organisers, who was also marking his birthday, told the Standard it had been a peaceful event before the fight broke out.

He said: "The incident happened around 11.45pm and the party was due to end at midnight."

Justin Timberlake dedicates iHeart Radio Award to 'different' people

Digital Justice in march to save elephants

The 91c column: Cote's transformed Chelsea players into superheroes

SPONSORED FEATURES

A guide to the UK's biggest art prizes

Move freely from town to country

Spring forward: next season's 10 best trends

I'm doing this for my dad

Weblog for news.rtc...

Browser window showing a news article from the Standard website. The URL is www.standard.co.uk/news/crime/i-thought-i-was-gonna-die-revellers-terror-as-man-stabbed-during-fight-on-jewel-of-london-thames-party-boat-a3491176.html. The page features a navigation bar with categories like News, Football, Going Out, Lifestyle, Showbiz, Homes & Property, and Food Month. The main headline reads: **'I thought I was gonna die': Revellers' terror as man stabbed during fight on Jewel of London Thames party boat**. The article text includes: "He said: 'The incident happened around 11.45pm and the party was due to end at midnight.' 'The party was organised to celebrate the birthdays of seven different people. It was a ticketed event and all attendees had to have a ticket prior to arrival.' 'I can't say much with regards the incident as I was not a witness to it personally but it occurred at the end of the night as people were about to disembark.' The RNL's Tower lifeboat and paramedics from London Ambulance Service were also drafted in. A Scotland Yard spokesman said three men had been found on board suffering from injuries and were taken to a north London hospital for treatment. One of the men, aged 21, was suffering from stab wounds and remains in hospital. His injuries are not thought to be life-threatening. The other two injured men, one aged 24 and the other aged 21, were later arrested on suspicion of affray. They are being questioned by police alongside another 21-year-old.

ES.  **'I thought I was gonna die': Revellers' terror as man stabbed during fight on Jewel of London Thames party boat**

He said: "The incident happened around 11.45pm and the party was due to end at midnight.

"The party was organised to celebrate the birthdays of seven different people. It was a ticketed event and all attendees had to have a ticket prior to arrival.

"I can't say much with regards the incident as I was not a witness to it personally but it occurred at the end of the night as people were about to disembark."

The RNL's Tower lifeboat and paramedics from London Ambulance Service were also drafted in.

A Scotland Yard spokesman said three men had been found on board suffering from injuries and were taken to a north London hospital for treatment.

One of the men, aged 21, was suffering from stab wounds and remains in hospital. His injuries are not thought to be life-threatening.

The other two injured men, one aged 24 and the other aged 21, were later arrested on suspicion of affray. They are being questioned by police alongside another 21-year-old.

www.standard.co.uk/going-out/this-is-guide-to-the-club-bigger-on-pizza-a3491176.html

128 [News](#) [Football](#) [Going Out](#) [Lifestyle](#) [Showbiz](#) [Homes & Property](#) [Food Month](#)

[Search](#) [User](#) [Menu](#)

[chefsitefu.com](#)

[drop](#)

[Win a year's cycling with Santander Cycles](#)

[dad](#)

EVIDENCE & ACTIONS BOOK

SUSPECT/PERSONNEL CONCERNED/ARRESTED

Robert
CAIRNS

ARREST/PROCESS INCIDENT

Breach of Police cordon cont.
to Sect 33 Terrorism Act 2000
Thurs day the 23rd March 2011
at 0030 time at Millbank Upper
mooring River Thames, Millbank
Westminster

Post Code

OFFICER REPORTING

Nick BULTITUDE

Warrant No.

195183

Rank

Pt

No

276

OCU Code

50020 MPU

Station

Wapping

Email

nick.bultitude

@met.police.uk

Book

1

of

Name of

CAIRNS

Accused

Custody No./

Unique Ref. No.

Stop/Search 5090 completed

Yes

No

CRIS No.

Other Ref. No.

- If physical force and/or officer safety equipment was used during the incident/arrest, give a detailed description of the use (describe technique used) and the reasons for use. You must tell the custody officer and, if appropriate, consult the FME. State what first aid was given.
 - If crime summons procedure was adopted rather than arrest, include reasons.
 - Remember to produce your exhibits.
- If you made or witnessed an arrest
- Record the words used to tell the person they were under arrest. The 'citation' is on page 2 (inside front cover).
 - Record the grounds.
 - Record the offence.
 - Record the necessity for arrest.
 - Please remember to cover points to prove the offence for which arrested.

MERLIN PAC

Incidents/arrests involving a person under the age of 18

Is there a concern about the child/young person not achieving one or more of the 5 ECM key outcomes: Be Healthy; Stay Safe; Enjoy and Achieve; Making a positive contribution; Economic Well-being.

Yes No - No further action necessary

MERLIN PAC Ref. No. _____

MERLIN PAC threshold not met - Action taken to address concerns recorded in notes

Supervisors: To ensure that where MERLIN threshold has been met a MERLIN PAC has been created.

WITNESS STATEMENT

CJ Act 1967, s.9 MC Act 1960, ss 5A(3)(a) and 5B; MC Rules 1981, r70

Statement of Nick Buttrose PC 2100

Age if under 18 _____ (if over 18 insert 'over 18')

Occupation Police Constable

This statement (consisting of 6 page(s) each signed by me) is true to the best of my knowledge and belief and I make it knowing that, if it is tendered in evidence, I shall be liable to prosecution if I have wilfully stated in it anything which I know to be false or do not believe to be true.

Date: 23/3/17 Time: 0300

Signature: N Buttrose

My name is Nick Buttrose and I am a police constable on the Marine Policing Unit of the Metropolitan Police Service. On Wednesday the 22nd March 2017 I was master of a marked police vessel named Sir Robert Peel called Marie 2. I was in company with PC TBCF LEE and SGT G BATTISBEE. Together we were tasked to the

Signature: N Buttrose

34
Westminster area following a terrorist attack on Westminster Bridge and Parliament. As part of the post-incident containment a cordon had been placed (under sect 33 Terrorism Act 2006) which included the River Thames. The extent of the closure ran upriver from Embankment Pier to Vauxhall Bridge. On arrival we were tasked with the security of the cordon and at 0830 hours (of the 23rd March) we were positioned alongside Millbank Pier at the upper end of the closure. I noticed a large passenger vessel I recognised as the Jewel of London navigating downriver and passing through Vauxhall Bridge. I called the boat on my VHF radio

Signature: *M. P. Baker*

35
Continued and informed the Master, a man I now know was Robert Carrens, that he had breached a police cordon and instructed him to turn about and head back upriver. The vessel continued towards us and Carrens said over the radio, "You better get out of the way I can't stop that quietly." I was aware that earlier in the day Carrens had requested to be allowed through the closure to meet the Jewel alongside his mooring at Millbank upper (inside the cordon). He was refused permission by Marine police and the VTS from the Port of London. I said to Carrens over the VHF "You have been told

M. P. Baker

Continued at least twice today³⁶
that you are not allowed
to enter the cordon, turn
your boat round or you
may be arrested. CAIENS
continued to slowly round
up and brought his vessel
alongside his barge where
his crewman (redacted)
dub (redacted) male (C1) started
to take lines and make
the boat fast. We drew
alongside and I crossed
on board. I met CAIENS
on the upper deck and
explained that we had breached
a police cordon set up under
the terrorist act following
the incident earlier in the
day and at 0815 hours I
reported him for the question
to be considered to prosecute
him for that offence. I captured
him and CAIENS replied "

Signature: *A. P. [redacted]*

Continued haven't in my eyes³⁷
done anything wrong. I
have 3 bar staff and a DT
who have been stuck on
here for hours. I've only just
come through the bridge to
get to my tender so I can
let them get home. I said
"but you knew the bridge
was closed and came through
without even calling up."
He said "I really didn't
think it would be an issue."
I made the decision not to
arrest CAIENS because to do
so would have taken my
boat off the water, leaving
the cordon vulnerable and
also because CAIENS' identity
was not in dispute. He
also had the welfare of
his crew in mind and needed
to run them ashore. As his
boat was tied and secure
in

Continued: and his crew ready to depart I took the decision to allow the vessel to remain where it was but with the condition that CAIRNS exited the area of the cordon ~~then~~ in his workboat immediately. He did so taking his crew and staff to St George Wharf Pier just outside the cordon where they were able to get ashore and make their way home. This report was made on my return to my station with the events fresh in my mind. ~~DATE: 23 MARCH 1987~~
MSB TH 23 MAR 87

Signature: *N. Buttles RSM*

Continued

[The remainder of the page is crossed out with a diagonal line.]

Continued: _____

Signature: _____

List details of other officers/units in attendance (e.g. van driver, other escorting officers, dog section, ARV, etc):

PC 713 CO JEREMY LEE
PC 5309 CO LIAM BATTERSBY

CHARGING/REPORTING NOTES

PERSON 1

CHARGED/TOLD REPORTED AND CAUTIONED:-

Time 0045 Date 23/3/17
Place on board Jewel of London.

OFFENCE(S) CHARGED/REPORTED:

Breach of a Police caution count to s87 83 Terrorism Act 2000.

PERSONS PRESENT:

PC 5309 CO BATTERSBY

REPLY:

I haven't in my eyes done anything wrong

RECORDED BY:

R 2200 Nick Burtmore

SIGNED:

N Battersby P.E.

PERSON CHARGED/REPORTED:

Report made after leaving

WITNESS STATEMENT

CJ Act 1967, s.9; MC Act 1980, ss.5A(3)(a) and 5B; Criminal Procedure Rules 2005, Rule 27.1

Statement of **Bryan Lewis PC4161CW** URN:

--	--	--	--

 Age if under 18 **Over 18**..... (if over 18 insert "over 18") Occupation: **Police Constable P200892**

This statement (consisting of: **2**..... pages each signed by me) is true to the best of my knowledge and belief and I make it knowing that, if it is tendered in evidence, I shall be liable to prosecution if I have wilfully stated anything in it which I know to be false, or do not believe to be true.

Signature: *Bryan Lewis PC4161CW* Date: **27th March 2017**



On Thursday 23rd of March 2017, I was the Police Officer in charge of the premises licence applications for the Jewel of London and Pearl of London party boats, on behalf of the Westminster Police Licensing Team. On this day there was to be a Westminster Licensing Sub Committee Hearing on the 17th Floor of Westminster City Hall, to hear both applications. While the Committee was deliberating over an earlier case that I was also representing on behalf of the Police, I was passed an email that had been received by my office from the Metropolitan Police Service, Marine Police Unit (SC020). The email was from an officer from that unit informing us of the following. That due to the Westminster terrorist incident the previous day, Wednesday 22/03/2017, a no entry Police cordon was enforced across the width of the river near Vauxhall Bridge, under Section 33 of the 2000 Terrorist Act. Mr Cairns had been instructed not to enter the cordon by Police but that he did so anyway. He therefore had been reported for this offence and that a crime report would be created. The email specifically stated that this incident was not a licensing issue but that it "goes to the character of Robbie Cairns", I notified a representative of the Westminster Council Licensing Team. A decision was made to notify the Sub Committee prior to the hearing. Due to sensitivity of the circumstances following the terrorist attack on Parliament, during which lives had been lost, including that of a Police Officer, an adjournment was considered the most appropriate course of action. Mr Cairns legal representative was not in favour of an adjournment therefore the Committee heard from Mr Cairns as to his explanation for the enforcement action by the Marine Police Unit. Due to him not providing any reasonable explanation or mitigating circumstances, a decision was made to adjourn the hearing to another date. I have subsequently received the Officer's notes on the case and have submitted them to form part of the evidence.

It is my opinion on behalf of the Metropolitan Police Service that Mr Cairns failure to act upon clear instructions from the Police during a time of extreme risk to the Public, following an actual terrorist attack nearby, does not provide us with confidence that he will be a responsible operator in charge of the safety of hundreds of persons who will use the services of his party boats.

Bryan Lewis PC4161CW

Signature: Signature witnessed by: